

FE



MATERIAL



Type Acetal resin with glass fibre
Designation BEARITE

FIELD OF APPLICATION



Fluids Hydraulic oils (mineral oil based)
For other fluids contact our technical department

SURFACE ROUGHNESS

Dynamic surface	$R_a \leq 0.3 \mu\text{m}$	$R_t \leq 2.5 \mu\text{m}$
Static surface	$R_a \leq 2 \mu\text{m}$	$R_t \leq 10 \mu\text{m}$

CHOICE OF GUIDE RING WIDTH

A rough estimate of guide width can be calculated with the following formula:

$$h_{mm} \geq \frac{F_N \times k}{p_{N/mm^2} \times d_{mm}}$$

where

- h_{mm} • Guide ring width in mm
- F_N • Radial load in N
- k • Safety factor (generally 2)
- d_{mm} • Rod diameter in mm
- p_{N/mm^2} • Surface pressure N/mm²
40 a 20 °C
30 a 70 °C

Before assembly good cleanliness and lubrication are recommended.

The above data are maximum values, they may be maintained for short periods and can not be used at the same time simultaneously.

The Aston Seals FE type guide rings have been developed to substitute traditional bronze guides in hydraulic cylinders. They guide the piston and prevent metallic contact with the cylinder when radial forces act perpendicular to the direction of movement.

Chamfered edges prevent the splintering of the material during assembly and make the installation into the groove easier.

The compound used for these guides is a medium viscosity glass fibre reinforced acetal resin characterized by high strength, rigidity, hardness, impact resistance, resilience and excellent stability to high and low temperature.

- Extended service life
- Excellent wear-resistance
- Simple design of groove and assembly
- Reduce vibrations
- Low friction
- Good resistance to loads
- Good mechanical stability at high temperature
- Easy installation without expensive auxiliaries

FE

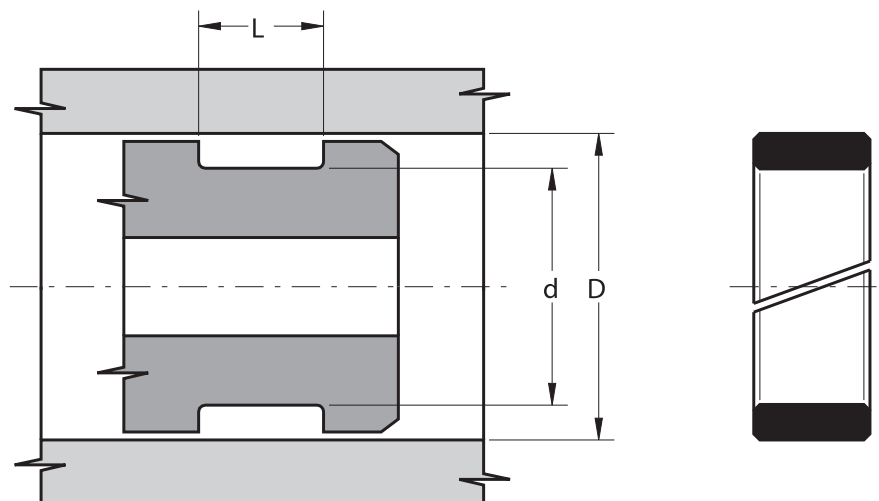

Part.	D ^{H8}	d ^{-0.05}	L ^{+0.25}
FE 16	16	12	9.6
FE 18	18	14	9.6
FE 20	20	16	9.6
FE 20 16 5.6	20	16	5.6
FE 22	22	18	9.6
FE 22 19 3.2	22	19	3.2
FE 24	24	20	9.6
FE 25 19 9.6	25	19	9.6
FE 25 21 8.2	25	21	8.2
FE 25	25	21	9.6
FE 26	26	22	9.6
FE 28	28	24	9.6
FE 28.58 25.4 9.78	28.58	25.4	9.78
FE 30	30	26	9.6
FE 32	32	28	9.6
FE 32 28 8.2	32	28	8.2
FE 34	34	30	9.6
FE 34.93 31.75 12.95	34.93	31.75	12.95
FE 35	35	31	9.6
FE 36	36	32	9.6
FE 38.1 31.75 12.95	38.1	31.75	12.95
FE 38.1 34.93 9.52	38.1	34.93	9.52
FE 40	40	36	9.6
FE 40 34 9.6	40	34	9.6

Part.	D ^{H8}	d ^{-0.05}	L ^{+0.25}
FE 40 36 12.2	40	36	12.2
FE 41.28 38.1 20.89	41.28	38.1	20.89
FE 42	42	38	9.6
FE 44 40 6.3	44	40	6.3
FE 45	45	41	9.6
FE 46	46	42	9.6
FE 47.5 44.45 20.89	47.5	44.45	20.89
FE 47.62 41.27 12.7	47.62	41.27	12.7
FE 48	48	42	9.6
FE 49	49	43	9.6
FE 50	50	44	9.6
FE 50.8 44.45 12.7	50.8	44.45	12.7
FE 50.8 44.45 12.95	50.8	44.45	12.95
FE 50.8 47.63 9.52	50.8	47.63	9.52
FE 53.97 47.62 19.05	53.97	47.62	19.05
FE 55	55	49	12.8
FE 55 49 9.6	55	49	9.6
FE 56	56	50	12.8
FE 57.15 50.8 25.65	57.15	50.8	25.65
FE 57.16 50.25 6.1	57.16	50.25	6.1
FE 60	60	54	12.8
FE 60 52 20.5	60	52	20.5
FE 60 54 9.6	60	54	9.6
FE 63	63	57	12.8

Part.	D ^{H8}	d ^{-0.05}	L ^{+0.25}
FE 63 57 10	63	57	10.0
FE 63.5 57.15 9.52	63.5	57.15	9.52
FE 63.5 57.15 12.7	63.5	57.15	12.7
FE 63.5 57.15 12.95	63.5	57.15	12.95
FE 63.5 60.33 9.52	63.5	60.33	9.52
FE 65	65	59	12.8
FE 69.85 63.5 12.7	69.85	63.5	12.7
FE 69.85 63.5 19.05	69.85	63.5	19.05
FE 69.85 63.5 25.65	69.85	63.5	25.65
FE 70	70	64	12.8
FE 74	74	68	12.8
FE 75	75	69	12.8
FE 75 69 9.6	75	69	9.6
FE 75 71 15.1	75	71	15.1
FE 76.2 69.85 9.65	76.2	69.85	9.65
FE 76.2 69.85 12.95	76.2	69.85	12.95
FE 80	80	74	12.8
FE 80 72 20.5	80	72	20.5
FE 82.55 79.38 9.52	82.55	79.38	9.52
FE 85	85	79	12.8
FE 88.9 82.55 19.3	88.9	82.55	19.3
FE 90 84 10	90	84	10.0
FE 90	90	84	12.8
FE 94	94	88	12.8

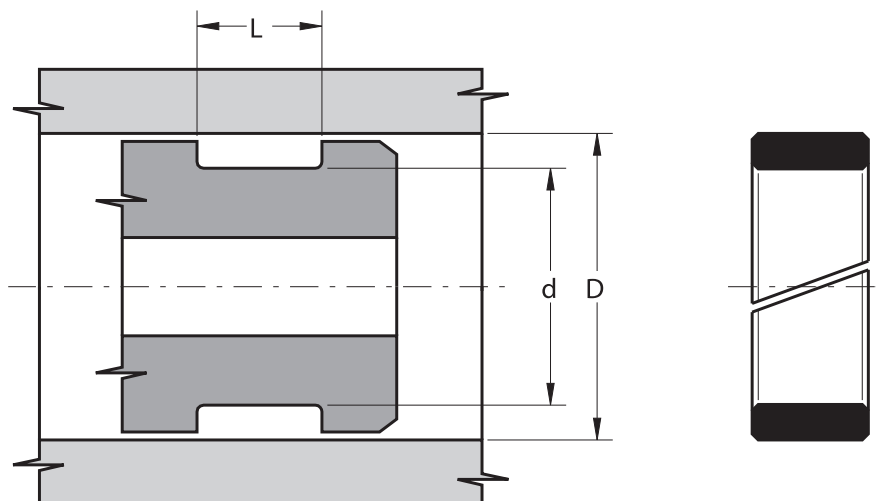

Part.	D ^{H8}	d ^{-0.05}	L ^{+0.25}
FE 95	95	89	12.8
FE 96	96	90	12.8
FE 100	100	94	12.8
FE 100 92 20.5	100	92	20.5
FE 101.6 95.25 25.65	101.6	95.25	25.65
FE 101.6 98.43 9.52	101.6	98.43	9.52
FE 105	105	99	12.8
FE 110	110	104	12.8
FE 115	115	109	12.8
FE 120	120	114	12.8
FE 120 112 20.5	120	112	20.5
FE 125	125	119	12.8
FE 126	126	120	12.8
FE 127 120.65 25.65	127	120.65	25.65
FE 127 123.83 9.52	127	123.83	9.52
FE 130	130	124	12.8
FE 135	135	129	12.8
FE 135 129 19.2	135	129	19.2
FE 140	140	134	12.8
FE 140 132 10.5	140	132	10.5
FE 140 132 20.5	140	132	20.5
FE 145	145	139	12.8

Part.	D ^{H8}	d ^{-0.05}	L ^{+0.25}
FE 147	147	141	12.8
FE 150	150	144	12.8
FE 152.4 146.05 12.7	152.4	146.05	12.7
FE 152.4 149.23 9.52	152.4	149.23	9.52
FE 155	155	149	19.2
FE 160	160	154	19.2
FE 160 152 20.5	160	152	20.5
FE 164 160 10.2	164	160	10.2
FE 165	165	159	19.2
FE 170	170	164	19.2
FE 175	175	169	19.2
FE 177.8 171.45 12.7	177.8	171.45	12.7
FE 180	180	174	19.2
FE 180 172 20.5	180	172	20.5
FE 184 180 10.2	184	180	10.2
FE 185	185	179	19.2
FE 190	190	184	19.2
FE 195	195	189	19.2
FE 198	198	192	19.2
FE 200	200	194	19.2
FE 205	205	199	19.2
FE 210	210	204	19.2

Part.	D ^{H8}	d ^{-0.05}	L ^{+0.25}
FE 215	215	209	19.2
FE 220	220	214	19.2
FE 220 216 10.2	220	216	10.2
FE 225	225	219	19.2
FE 230	230	224	19.2
FE 235	235	229	19.2
FE 240	240	234	19.2
FE 245	245	239	19.2
FE 250	250	244	19.2
FE 250 246 20.2	250	246	20.2
FE 255	255	249	19.2
FE 260	260	254	19.2
FE 265	265	259	19.2
FE 270	270	264	19.2
FE 275	275	269	19.2
FE 280	280	274	19.2
FE 285	285	279	19.2
FE 290	290	284	19.2
FE 295	295	289	19.2
FE 300	300	294	19.2

